

# BETAMAX COMBO - RIGHT EXIT - 42"

## AUTOMATIC FLATBREAD PRESS, STAND, OVEN & DTL

TOP VIEW

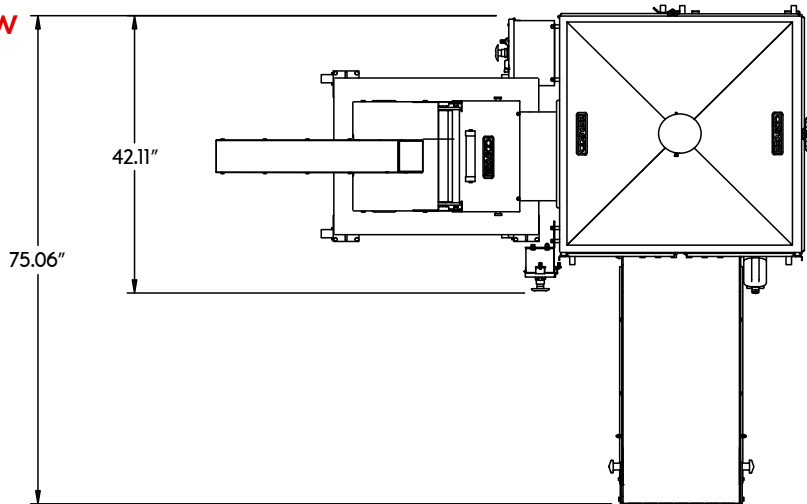

SIDE VIEW

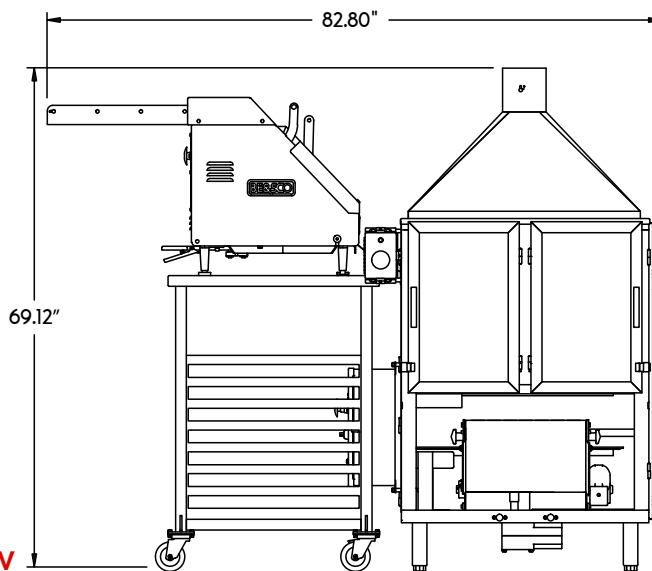

DIAMETER FROM  
4" TO 13"



900/HR.  
HIGH  
PRODUCTION







TEMPERATURE  
CONTROLLED  
PLATES



AUTOMATIC



THICKNESS  
ADJUSTMENT

PRESS VOLTS	220V/240V	OVEN VOLTS	240V
PRESS AMPS	23.4	OVEN AMPS	3
PRESS CYCLES	60HZ	OVEN POWER (GAS)	100000 BTU/HR
PRESS POWER	5600 WATTS	OVEN ELECTRICAL (240V)	 PLUG: NEMA 6-20P (250V~)  RECEPTACLE: NEMA 6-20R (250V~)
PRESS ELECTRICAL	 PLUG: NEMA 10-50P (250V~)  RECEPTACLE: NEMA 10-50R (250V~)	COMBO WEIGHT	1030LBS.
COMBO DIMENSIONS	75.06" L X 82.80" W X 69.12" H		



\*Certifications Applicable to Press and Oven Only. Certifications Not Applicable to Stands.

\*\*Production may vary due to the operator experience, diameter and thickness of product.

BESCO EQUIPMENT IS SOLELY INTENDED FOR USE IN A COMMERCIAL FACILITY.



REVISED: 07/27/2023